

Amtron Technology, Inc.

Industrial Grade 2.5" SATA III SSD AC Series Product Datasheet

V1.3

Table of Contents

1.	Introduction	3
1.1.	General Description	3
1.2.	Product Features	3
1.3.	Product Overview	4
1.4.	Block Diagram.....	5
2.	Product Specifications.....	6
2.1.	Product Dimension	6
2.2.	Capacity and Performance	7
2.3.	Compliance	10
3.	Environmental Specifications	11
3.1.	Environmental Conditions	11
3.1.1.	Temperature and Humidity	11
3.1.2.	Shock	12
3.1.3.	Vibration	12
3.1.4.	Drop	12
3.1.5.	Bending.....	12
3.1.6.	Electrostatic Discharge (ESD).....	12
3.2.	Certification	12
4.	Electrical Specifications	13
4.1.	Supply Voltage	13
4.2.	Power Consumption.....	13
5.	Interface.....	15
5.1.	Pin Assignment and Descriptions	15
6.	Supported Commands.....	16
6.1.	ATA Command List	16
6.2.	Identify Device Data.....	18
6.3.	Write Protect Function (Optional)	23
6.4.	Quick Erase Function (Optional).....	23
7.	Acromym	24
8.	Part Number Decoder.....	25

1. INTRODUCTION



1.1. General Description

Amtron industrial grade AC series 2.5" SATA SSD delivers all the advantages of flash disk technology with Serial ATA I/II/III interface, with features of low power consumption and hot-swapping when removing, replacing, upgrading flash disks. The device is designed based on the standard 7-pin interface for data segment and 15-pin for power segment.

Amtron AC series 2.5" SATA SSDs are available in a wide range from 16GB up to 2TB. It can reach high performance of up to 550MB/s read and 500MB/s write speed.

1.2. Product Features

- 3D TLC NAND flash
- RoHS compliant [Lead free]
- Compliant with SATA Specification 3.2
- High speed:
 - Read: 550 MB/s max., Write: 500 MB/s max.
- Endure severe thermal and dynamic environments
 - Operation Temperature (Wide grade): -40°C to 85°C
 - Shock: 1500g
 - Vibration: 20g
- Very low power consumption
- MTBF: 2,000,000 hours
- Support S.M.A.R.T. Command
- Optional features
 - Power Loss Protection
 - Quick Erase
 - Write Protection
 - Conformal Coating
- Controlled Bill of Materials (BOM)

1.3. Product Overview

- **SATA Interface**
 - SATA Revision 3.2
 - SATA 1.5Gbps, 3Gbps, and 6Gbps interface
- **Flash Interface**
 - Flash Type: 3D TLC
- **Capacity**
 - 16GB up to 2TB
- **Performance**
 - Read up to 550 MB/s
 - Write up to 500 MB/s
- **Power Consumption²**
 - Active mode: < 1,850 mW
 - Idle mode: < 330 mW
- **Low Power Management**
 - DIPM/HIPM Mode
 - DEVSLP Mode (optional)
- **MTBF¹**
 - 2,000,000 hours
- **Advanced Flash Management**
 - Bad Block Management
 - TRIM
 - SMART
 - Over-Provision
- **Temperature Range**
 - Operation (Standard): 0°C to 70°C
 - Operation (Wide): -40°C to 85°C
 - Storage: -40°C ~ 85°C
- **Other Optional Features**
 - Power Loss Protection
 - Quick Erase
 - Write Protect
 - Conformal Coating
- **Compliant**
 - RoHS
 - CE & FCC

Notes:

1. MTBF, an acronym for Mean Time between Failures, is a measure of a device's reliability. Its value represents the average time between a repair and the next failure. The measure is typically in unit of hours. The higher the MTBF value, the higher the reliability of the product.
2. Please see Section 4.2 "Power Consumption" for details.

1.4. Block Diagram

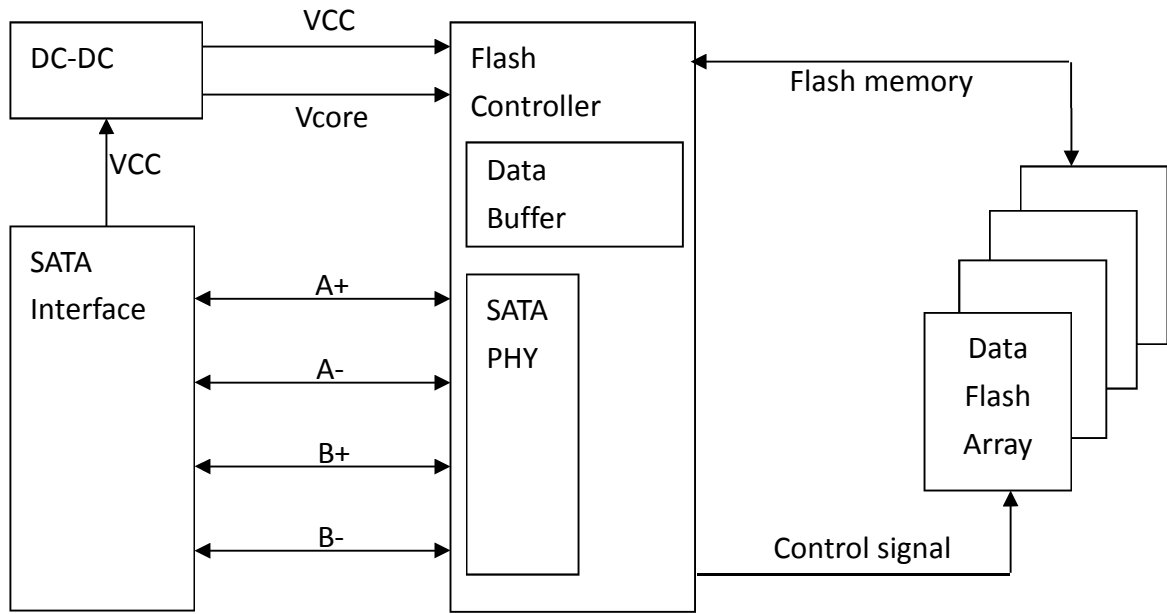

2.5" SATA SSD Block Diagram

2. PRODUCT SPECIFICATIONS



2.1. Product Dimension

Dimension: 100.10mm(L) x 69.85mm(W) x 7.00mm(H)

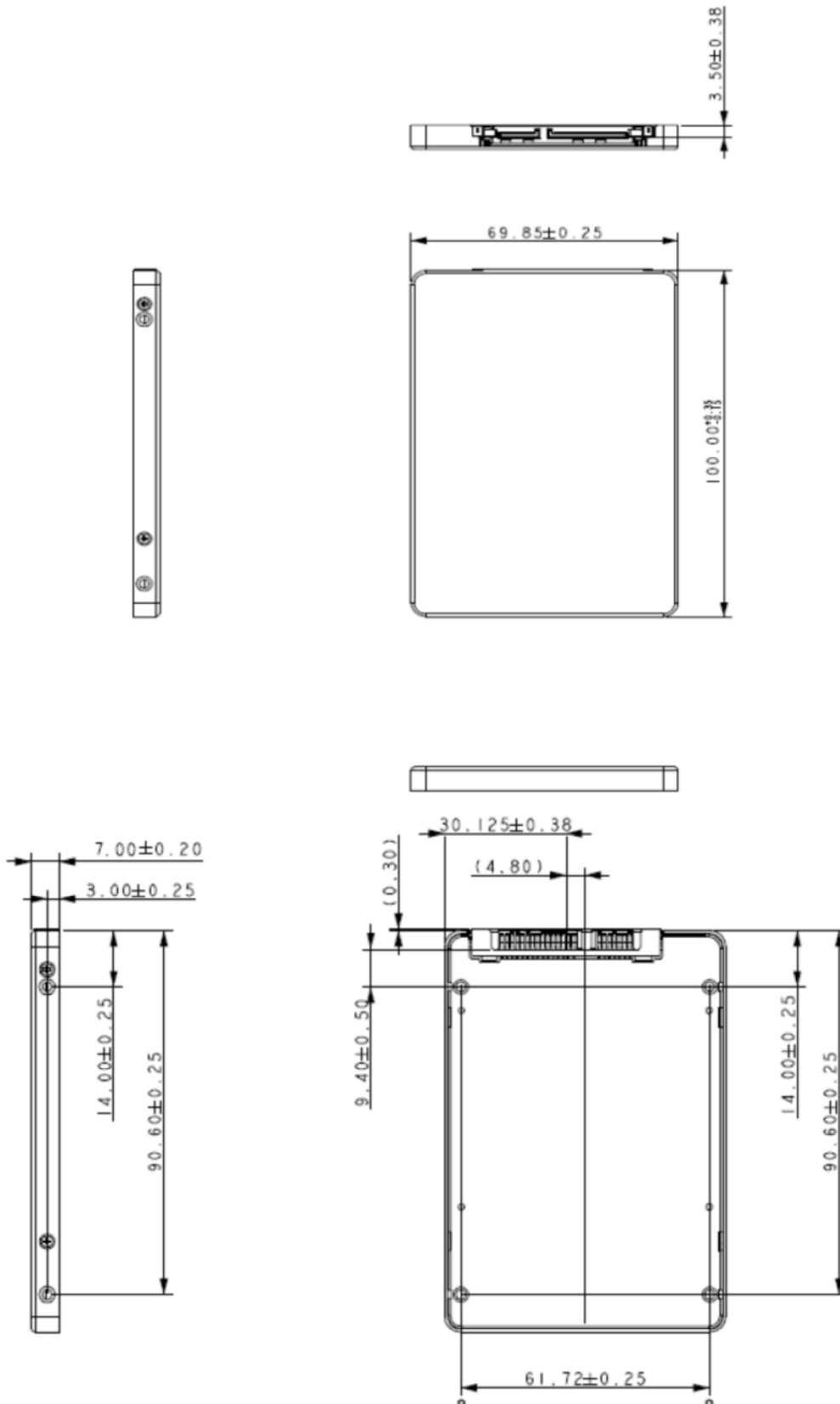

2.2. Capacity and Performance

- **Capacity**
 - 16GB up to 2TB (support 48-bit addressing mode)
- **Electrical/Physical Interface**
 - SATA Interface
 - ◆ Compliant with SATA Revision 3.2
 - ◆ Compatible with SATA 1.5Gbps, 3Gbps and 6Gbps interface
 - ◆ Support ATA-8 command set
- **Built-in 4-channel NAND flash interface controller**
 - Enhanced endurance by dynamic/static wear-leveling
 - AgileECC 2 which includes:
 - ◆ Hardware-based V.P.R (Virtual Parity Recovery)
 - ◆ Support 2K Byte code-word length
 - ◆ Support Shift read/Read Retry feature of NAND flash
 - ◆ Read Disturb protection
 - ◆ Data integrity under power-cycling
- **Supported NAND Flash**
 - Support Toggle 2.0 and ONFi 4.0 all types of 3D-NAND, up to 667MHz
- **Support SMART and TRIM commands**
- **Support Hardware Write Protect function (optional)**
- **Support Hardware Quick Erase function (optional)**
- **Support Hardware Power Loss Protection (Optional)**
 - Protect data loss, even the last data, during write process when power sudden off.
 - Add-on Polymer Tantalum Capacitors hold-up several milliseconds to keep Cache data write to NAND Flash.

● Capacity Information

Capacity	Cylinders	Heads	Sectors	Total Sectors	User Data Size
16GB	16,383	16	63	31,277,232	Depended on file management
32GB	16,383	16	63	62,533,296	
60GB	16,383	16	63	117,231,408	
64GB	16,383	16	63	125,045,424	
120GB	16,383	16	63	234,441,648	
128GB	16,383	16	63	250,069,680	
240GB	16,383	16	63	468,862,128	
256GB	16,383	16	63	500,118,192	
480GB	16,383	16	63	937,703,088	
512GB	16,383	16	63	1,000,215,216	
960GB	16,383	16	63	1,875,385,008	
1TB	16,383	16	63	2,000,409,264	
1920GB	16,383	16	63	3,750,748,848	
2TB	16,383	16	63	4,000,797,360	

- Performance

Capacity	Flash Structure	Flash Type	Sequential	
			Read (MB/s)	Write (MB/s)
60GB	64GB x 1	BiCS3, BGA, 256Gb DDP	420	250
120/128GB	64GB x 2	BiCS3, BGA, 256Gb DDP	550	470
240/256GB	128GB x 2	BiCS3, BGA, 256Gb QDP	550	490
480/512GB	256GB x 2	BiCS3, BGA, 256Gb ODP	550	490
60GB	64GB x 1	BiCS4, BGA, 256Gb DDP	430	280
120/128GB	64GB x 2	BiCS4, BGA, 256Gb DDP	550	480
240/256GB	128GB x 2	BiCS4, BGA, 512Gb DDP	550	420
	64GB x 4	BiCS4, BGA, 256Gb DDP	550	490
480/512GB	256GB x 2	BiCS4, BGA, 512Gb QDP	550	490
960GB/1TB	256GB x 4	BiCS4, BGA, 512Gb QDP	550	490
1920GB/2TB	512GB x 4	BiCS4, BGA, 512Gb ODP	550	490
120GB	64GB x 2	B17A, BGA, 512Gb SDP	520	425
240/256GB	128GB x 2	B17A, BGA, 512Gb DDP	550	475
480/512GB	256GB x 2	B17A, BGA, 512Gb QDP	550	490
960GB/1TB	256GB x 4	B17A, BGA, 512Gb QDP	550	490
1920GB/2TB	512GB x 4	B17A, BGA, 512Gb ODP	550	490
16GB	64GB x 1	BiCS3 pSLC, BGA, 256Gb DDP	420	250
32GB	64GB x 2	BiCS3 pSLC, BGA, 256Gb DDP	550	480
64GB	128GB x 2	BiCS3 pSLC, BGA, 256Gb QDP	550	490
128GB	256GB x 2	BiCS3 pSLC, BGA, 256Gb ODP	550	490
256GB	256GB x 4	BiCS3 pSLC, BGA, 256Gb ODP	550	490
64GB	128GB x 2	BiCS4 pSLC, BGA, 512Gb DDP	550	420
128GB	256GB x 2	BiCS4 pSLC, BGA, 512Gb QDP	550	500
256GB	256GB x 4	BiCS4 pSLC, BGA, 512Gb QDP	550	500
512GB	512GB x 4	BiCS4 pSLC, BGA, 512Gb ODP	550	500

Notes:

1. The performance was estimated based on 3D NAND flash.
2. Performance may differ according to flash configuration and platform.
3. The table above is for reference only.

- **TBW (Terabytes Written)**

Capacity	Flash Structure	TBW
60GB	Bics3, 64GB x 1	85
120/128GB	Bics3, 64GB x 2	221
240/256GB	Bics3, 128GB x 2	536
480/512GB	Bics3, 256GB x 2	1162
60GB	Bics4, 64GB x 1	75
120/128GB	Bics4, 64GB x 2	191
240/256GB	Bics4, 128GB x 2	455
480/512GB	Bics4, 256GB x 2	1128
960GB/1TB	Bics4, 256GB x 4	2174
1920GB/2TB	Bics4, 512GB x 4	4317
120GB	B17A, 64GB x 2	183
240/256GB	B17A, 128GB x 2	455
480/512GB	B17A, 256GB x 2	1095
960GB/1TB	B17A, 256GB x 4	2381
1920GB/2TB	B17A, 512GB x 4	4445
16GB	Bics3 pSLC, 64GB x 1	469
32GB	Bics3 pSLC, 64GB x 2	953
64GB	Bics3 pSLC, 128GB x 2	1817
128GB	Bics3 pSLC, 256GB x 2	3973
256GB	Bics3 pSLC, 256GB x 4	7268
64GB	Bics4 pSLC, 128GB x 2	1288
128GB	Bics4 pSLC, 256GB x 2	3256
256GB	Bics4 pSLC, 256GB x 4	7441
512GB	Bics4 pSLC, 512GB x 4	15757

Notes:

1. Samples were built using 3D NAND flash.
2. The test followed JEDEC219A client endurance workload.
3. TBW may differ according to flash configuration and platform.
4. The endurance of SSD could be estimated based on user behavior, NAND endurance cycles, and write amplification factor. It is not guaranteed by flash vendor.

2.3. Compliance

- SATA III (SATA Rev. 3.2)
- Up to ATA/ATAPI-8 (Including S.M.A.R.T)

3. ENVIRONMENTAL SPECIFICATIONS



3.1. Environmental Conditions

3.1.1. Temperature and Humidity

- Temperature:
 - ◆ Storage: -40°C to 85°C
 - ◆ Operational (Standard grade): 0°C to 70°C
 - ◆ Operational (Wide grade): -40°C to 85°C
- Humidity:
 - ◆ Standard grade: RH 90% under 40°C (operational)
 - ◆ Wide grade: RH 95% under 55°C (operational)

■ High Temperature Test Condition

	Temperature	Humidity
Operation	70°C / 85°C	0% RH
Storage	85°C	0% RH

■ Low Temperature Test Condition

	Temperature	Humidity
Operation	0°C / -40°C	0% RH
Storage	-40°C	0% RH

■ High Humidity Test Condition

	Temperature	Humidity
Operation	40°C	90% RH
Storage	40°C	93% RH

■ Temperature Cycle Test

	Temperature
Operation	0°C / -40°C
	70°C / 85°C
Storage	-40°C
	85°C

3.1.2. Shock

■ Shock Specification

	Acceleration Force
Non-operational	1500G

3.1.3. Vibration

■ Vibration Specification

	Condition	
	Frequency/Displacement	Frequency/Acceleration
Non-operational	20Hz~80Hz/1.52mm	80Hz~2000Hz/20G

3.1.4. Drop

■ Drop Specification

	Height of Drop	Number of Drop
Non-operational	80cm free fall	6 face of each unit

3.1.5. Bending

■ Bending Specification

	Force	Action
Non-operational	≥ 20N	Hold 1min/5times

3.1.6. Electrostatic Discharge (ESD)

■ Contact ESD Specification

Device	Capacity	Temperature	Relative Humidity	+/- 4KV	Result
2.5" SSD	480GB	24.0°C	49% (RH)	Device functions are affected, but EUT will be back to its normal or operational state automatically.	PASS

3.2. Certification

- RoHS
- CE / FCC

4. ELECTRICAL SPECIFICATIONS



4.1. Supply Voltage

Parameter	Rating
Operating Voltage	5V , ±5%

4.2. Power Consumption

Capacity	Flash Structure	Flash Type	Read	Write	Idle
60GB	64GB x 1	BiCS3, BGA, 256Gb DDP	1,300	1,200	310
120/128GB	64GB x 2	BiCS3, BGA, 256Gb DDP	1,500	1,500	310
240/256GB	128GB x 2	BiCS3, BGA, 256Gb QDP	1,600	1,600	310
480/512GB	256GB x 2	BiCS3, BGA, 256Gb ODP	1,600	1,600	310
60GB	64GB x 1	BiCS4, BGA, 256Gb DDP	1,000	1,000	230
120/128GB	64GB x 2	BiCS4, BGA, 256Gb DDP	1,000	1,000	220
240/256GB	128GB x 2	BiCS4, BGA, 512Gb DDP	1,200	1,200	220
	64GB x 4	BiCS4, BGA, 256Gb DDP	1,500	1,500	300
480/512GB	256GB x 2	BiCS4, BGA, 512Gb QDP	1,200	1,200	240
960GB/1TB	256GB x 4	BiCS4, BGA, 512Gb QDP	1,500	1,500	300
1920GB/2TB	512GB x 4	BiCS4, BGA, 512Gb ODP	1,500	1,500	300
120GB	64GB x 2	B17A, BGA, 512Gb SDP	1,000	1,000	220
240/256GB	128GB x 2	B17A, BGA, 512Gb DDP	1,100	1,100	220
480/512GB	256GB x 2	B17A, BGA, 512Gb QDP	1,100	1,100	220
960GB/1TB	256GB x 4	B17A, BGA, 512Gb QDP	1,600	1,600	310
1920GB/2TB	512GB x 4	B17A, BGA, 512Gb ODP	1,600	1,600	310
16GB	64GB x 1	BiCS3 pSLC, BGA, 256Gb DDP	1,300	1,200	300
32GB	64GB x 2	BiCS3 pSLC, BGA, 256Gb DDP	1,700	1,800	320
64GB	128GB x 2	BiCS3 pSLC, BGA, 256Gb QDP	1,700	1,800	320
128GB	256GB x 2	BiCS3 pSLC, BGA, 256Gb ODP	1,700	1,800	310
256GB	256GB x 4	BiCS3 pSLC, BGA, 256Gb ODP	1,700	1,800	310
64GB	128GB x 2	BiCS4 pSLC, BGA, 512Gb DDP	1,650	1,750	330
128GB	256GB x 2	BiCS4 pSLC, BGA, 512Gb QDP	1,700	1,850	330
256GB	256GB x 4	BiCS4 pSLC, BGA, 512Gb QDP	1,700	1,850	330
512GB	512GB x 4	BiCS4 pSLC, BGA, 512Gb ODP	1,700	1,850	330

Unit: mW

Notes:

- The measured power voltage is 5V.

2. Samples were built using 3D NAND flash and measured under normal temperature.
3. Sequential R/W is measured while testing 1000MB sequential R/W 5 times by CrystalDiskMark.
4. Power Consumption may differ according to flash configuration and platform.

5. INTERFACE



5.1. Pin Assignment and Descriptions

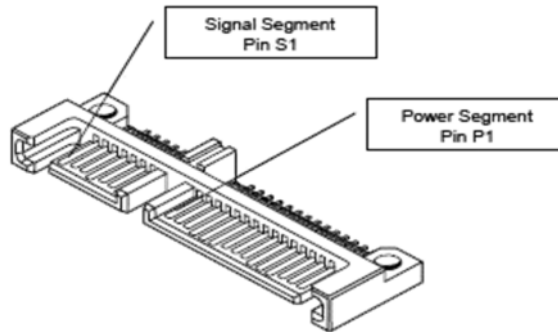

Signal Segment Pin Assignment	Pin Number	Function
	S1	GND
	S2	A+ (Differential Signal Pair A)
	S3	A – (Differential Signal Pair A)
	S4	GND
	S5	B – (Differential Signal Pair B)
	S6	B+ (Differential Signal Pair B)
	S7	GND
Power Segment Pin Assignment	Pin Number	Function
	P1	Not Used (3.3V)
	P2	Not Used (3.3V)
	P3	DEVSLP
	P4	GND
	P5	GND
	P6	GND
	P7	5V
	P8	5V
	P9	5V
	P10	GND
	P11	Reserved for DAS LED
	P12	GND
	P13	Not Used (12V pre-charge)
	P14	Not Used (12V)
P15	Not Used (12V)	

6. SUPPORTED COMMANDS



6.1. ATA Command List

Op-Code	Command Description		Op-Code	Command Description	
00h	NOP		60h	Read FPDMA Queued	
06h	Data Set Management		61h	Write FPDMA Queued	
10h	Recalibrate		70h	Seek	
20h	Read Sectors		90h	Execute Device Diagnostic	
21h	Read Sectors without Retry		91h	Initialize Device Parameters	
24h	Read Sectors EXT		92h	Download Microcode	
25h	Read DMA EXT		93h	Download Microcode DMA	
27h	Read Native Max Address EXT		B0h	SMART	
29h	Read Multiple EXT		B0h	D0h	SMART READ DATA
2Fh	Read Log EXT		B0h	D1h	SMART READ DATA ATTRIBUTE THRESHOLD
30h	Write Sectors		B0h	D2h	SMART ENABLE/DISABLE ATTRIBUTE AUTOSAVE
31h	Write Sectors without Retry		B0h	D3h	SMART SAVE ATTRIBUTE VALUES
34h	Write Sectors EXT		B0h	D4h	SMART EXECUTE OFF-LINE IMMEDIATE
35h	Write DMA EXT		B0h	D5h	SMART READ LOG
37h	Set Native Max Address EXT		B0h	D6h	SMART WRITE LOG
39h	Write Multiple EXT		B0h	D8h	SMART ENABLE OPERATIONS
3Dh	Write DMA FUA EXT		B0h	D9h	SMART DISABLE OPERATIONS
3Fh	Write Long EXT		B0h	DAh	SMART RETURN STATUS
40h	Read Verify Sectors		B0h	DBh	SMART ENABLE/DISABLE AUTOMATIC OFF-LINE
41h	Read Verify Sectors without Retry		B1h	DEVICE CONFIGURATION OVERLAY	
42h	Read Verify Sectors EXT		B1h	C0h	DEVICE CONFIGURATION RESTORE
45h	Write Uncorrectable EXT		B1h	C1h	DEVICE CONFIGURATION FREEZE LOCK
47h	Read Log DMA EXT		B1h	C2h	DEVICE CONFIGURATION IDENTIFY
57h	Write Log DMA EXT		B1h	C3h	DEVICE CONFIGURATION SET
B1h	C4h	DEVICE CONFIGURATION IDENTIFY DMA	ECh	Identify Device	
B1h	C5h	DEVICE CONFIGURATION SET DMA	EFh	Set Features	
C4h	Read Multiple		EFh	02h	Enable 8-bit PIO transfer mode
Op-Code	Command Description		Op-Code	Command Description	

C5h	Write Multiple	EFh	03h		Set transfer mode based on value in Count field
C6h	Set Multiple Mode	EFh	05h		Enable advanced power management
C8h	Read DMA	EFh	10h		Enable use of Serial ATA feature
C9h	Read DMA without Retry	EFh	10h	02h	Enable DMA Setup FIS Auto-Activate optimization
CAh	Write DMA	EFh	10h	03h	Enable Device-initiated interface power state (DIPM) transitions
CBh	Write DMA without Retry	EFh	10h	06h	Enable Software Settings Preservation (SSP)
CEh	Write Multiple FUA EXT	EFh	10h	07h	Enable Device Automatic Partial to Slumber transitions
E0h	Standby Immediate	EFh	10h	09h	Enable Device Sleep
E1h	Idle Immediate	EFh	55h		Disable read look-ahead feature
E2h	Standby	EFh	66h		Disable reverting to power-on defaults
E3h	Idle	EFh	82h		Disable write cache
E4h	Read Buffer	EFh	85h		Disable advanced power management
E5h	Check Power Mode	EFh	90h		Disable use of Serial ATA feature set
E6h	Sleep	EFh	90h	02h	Disable DMA Setup FIS Auto-Activate optimization
E7h	Flush Cache	EFh	90h	03h	Disable Device-initiated interface power state (DIPM) transitions
E8h	Write Buffer	EFh	90h	06h	Disable Software Settings Preservation (SSP)
E9h	Read Buffer DMA	EFh	90h	07h	Disable Device Automatic Partial to Slumber transitions
EAh	Flush Cache EXT	EFh	90h	09h	Disable Device Sleep
EBh	Write Buffer DMA	EFh	AAh		Enable read look-ahead feature
EFh	CCh	Enable reverting to power-on defaults		F4h	Security Erase Unit
F1h	Security Set Password		F5h	Security Freeze Lock	
F2h	Security Unlock		F6h	Security Disable Password	
F3h	Security Erase Prepare		F8h	Read Native Max Address	

6.2. Identify Device Data

The following table details the sector data returned by the IDENTIFY DEVICE command.

Word	F: Fixed V: Variable X: retired/obsolete /reserved	Default Value	Description
0	F	0040h	General configuration bit-significant information
1	X	*1	Obsolete – Number of logical cylinders
2	F	C837h	Specific configuration
3	X	0010h	Obsolete – Number of logical heads (16)
4-5	X	00000000h	Retired
6	X	003Fh	Obsolete – Number of logical sectors per logical track (63)
7-8	X	00000000h	Reserved for assignment by the Compact Flash Association
9	X	0000h	Retired
10-19	V	Varies	Serial number (20 ASCII characters)
20-21	X	0000h	Retired
22	X	0000h	Obsolete
23-26	V	Varies	Firmware revision (8 ASCII characters)
27-46	V	Varies	Model number (xxxxxxx)
47	F	8010h	7:0- Maximum number of sectors transferred per interrupt on MULTIPLE commands
48	F	4000h	Reserved
49	F	2F00h	Capabilities
50	F	4000h	Capabilities
51-52	X	000000000h	Obsolete
53	F	0007h	Words 88 and 70:64 valid
54	X	*1	Obsolete – Number of logical cylinders
55	X	0010h	Obsolete – Number of logical heads (16)
56	X	003Fh	Obsolete – Number of logical sectors per track (63)
57-58	X	*2	Obsolete – Current capacity in sectors
59	F	0110h	Number of sectors transferred per interrupt on MULTIPLE commands
60-61	V	*3	Maximum number of sector (28bit LBA mode)
62	X	0000h	Obsolete
63	F	0407h	Multi-word DMA modes supported/selected

Word	F: Fixed V: Variable X: retired/obsolete /reserved	Default Value	Description
64	F	0003h	PIO modes supported
65	F	0078h	Minimum Multiword DMA transfer cycle time per word
66	F	0078h	Manufacturer's recommended Multiword DMA transfer cycle time
67	F	0078h	Minimum PIO transfer cycle time without flow control
68	F	0078h	Minimum PIO transfer cycle time with IORDY flow control
69	F	1F00h	Additional Supported
70	X	0000h	Reserved
71-74	X	000000000000 0000h	Reserved for the IDENTIFY PACKET DEVICE command
75	F	001Fh	Queue depth
76	F	850Eh	Serial SATA capabilities
77	F	0006h	Supported Serial ATA Phy speed
78	F	004Ch	Serial ATA features supported
79	F	0040H	Serial ATA features enabled
80	F	0FF8h	Major Version Number
81	F	0000h	Minor Version Number
82	F	746Bh	Command set supported
83	F	7D01h	Command set supported
84	F	4163h	Command set/feature supported extension
85	F	7469h	Command set/feature supported or enabled
86	F	BC01h	Command set/feature supported or enabled
87	F	4163h	Command set/feature supported or enabled
88	F	007Fh	Ultra DMA Modes
89	F	000Ah	Time required for Normal Erase mode SECURITY ERASE UNIT command
90	F	001Eh	Time required for an Enhanced Erase mode SECURITY ERASE UNIT command
91	F	0000h	Current advanced power management value
92	F	FFFEh	Master Password Revision Code
93	F	0000h	Hardware reset result. The contents of the bits (12:0) of this word can be changed only during the execution of hardware reset.

Word	F: Fixed V: Variable X: retired/obsolete /reserved	Default Value	Description
94	X	0000h	Vendor's recommended and actual acoustic management value
95	F	0000h	Stream Minimum Request Size
96	F	0000h	Streaming Transfer Time – DMA
97	F	0000h	Streaming Access Latency – DMA and PIO
98-99	F	0000h	Streaming Performance Granularity
100-103	V	*4	Maximum user LBA for 48 bit Address feature set
104	F	0000h	Streaming Transfer Time – PIO
105	F	0008h	Maximum number of 512-byte blocks per DATA SET MANAGEMENT command
106	F	4000h	Physical sector size/Logical sector size
107	F	0000h	Inter-seek delay for ISO-7779 acoustic testing in microseconds
108-111	F	Varies	Reserved
112-115	X	000000000000 0000h	Reserved
116	X	0000h	Reserved
117-118	F	00000000h	Words per logical Sector
119	F	401Ch	Supported settings
120	F	401Ch	Command set/Feature Enabled/Supported
121-126	X	0h	Reserved
127	X	0h	Obsolete
128	F	0021h	Security status
129-159	V	Varies	Vendor specific
160	X	0h	Compact Flash Association (CFA) power mode 1
161-167	X	0h	Reserved for assignment by the CFA
168	V	Varies	Device Nominal Form Factor
169	F	0001h	DATA SET MANAGEMENT command is supported
170-173	F	0h	Additional Product Identifier
174-175	X	0h	Reserve
176-205	F	0h	Current media serial number
206	F	0039h	SCT Command Transport

Word	F: Fixed V: Variable X: retired/obsolete /reserved	Default Value	Description
207-208	X	0h	Reserved
209	F	4000h	Alignment of logical blocks within a physical block
210-211	F	0000h	Write-Read-Verify Sector Count Mode 3 (not support)
212-213	F	0000h	Write-Read-Verify Sector Count Mode 2 (not support)
214-216	X	0000h	NV Cache relate (not support)
217	F	0001h	Non-rotating media device
218	X	0h	Reserved
219	X	0h	NV Cache relate (not support)
220	V	0h	Write read verify feature set current mode
221	X	0h	Reserved
222	F	10FFh	Transport major version number
223	F	0h	Transport minor version number
224-229	X	0h	reserved
230-233	F	0h	Extend number of user addressable sectors
234	F	0001h	Minimum number of 512-byte data blocks per DOWNLOAD MICROCODE command for mode 03h
235	F	FFFEh	Maximum number of 512-byte data blocks per DOWNLOAD MICROCODE command for mode 03h
236-242	X	0h	Reserved
243	X	0000h	Reserved
244-254	X	0h	Reserved
255	F	XXA5h XX is variable	Integrity word (Checksum and Signature)

■ List of Device Identification for Each Capacity

Capacity (GB)	*1 (Word 1/Word 54)	*2 (Word 57–58)	*3 (Word 60–61)	*4 (Word 100–103)
16	3FFFh	FBFC10h	2547C30h	2547C30h
32	3FFFh	FBFC10h	4A8A5B0h	4A8A5B0h
60	3FFFh	FBFC10h	6FCCF30h	6FCCF30h
64	3FFFh	FBFC10h	7740AB0h	7740AB0h
120	3FFFh	FBFC10h	DF94BB0h	DF94BB0h
128	3FFFh	FBFC10h	EE7C2B0h	EE7C2B0h
240	3FFFh	FBFC10h	0FFFFFFFh	1BF244B0h
256	3FFFh	FBFC10h	0FFFFFFFh	1DCF32B0h
480	3FFFh	FBFC10h	0FFFFFFFh	37E436B0
512	3FFFh	FBFC10h	0FFFFFFFh	3B9E12B0h
960	3FFFh	FBFC10h	0FFFFFFFh	6FC81AB0h
1024	3FFFh	FBFC10h	0FFFFFFFh	773BD2B0h
1920	3FFFh	FBFC10h	0FFFFFFFh	DF8FE2B0h
2048	3FFFh	FBFC10h	0FFFFFFFh	EE7752B0h

6.3. Write Protect Function (Optional)

The write protect function is triggered by pin1 and pin2 short of pin header. This used to set the device as a write protection device after power up. When the function is triggered, the data can't be written to the device. The device is then set as read only.

6.4. Quick Erase Function (Optional)

The Quick Erase is a special feature to allow users to erase user data of SSD by hardware trigger. When this feature is triggered by pin3 and pin4 short of pin header, the SSD controller will write all "0x00" to wipe all the data except firmware area, and the SSD will return to its factory default setting. This feature is particularly useful for emergent circumstances to quickly erase user data.

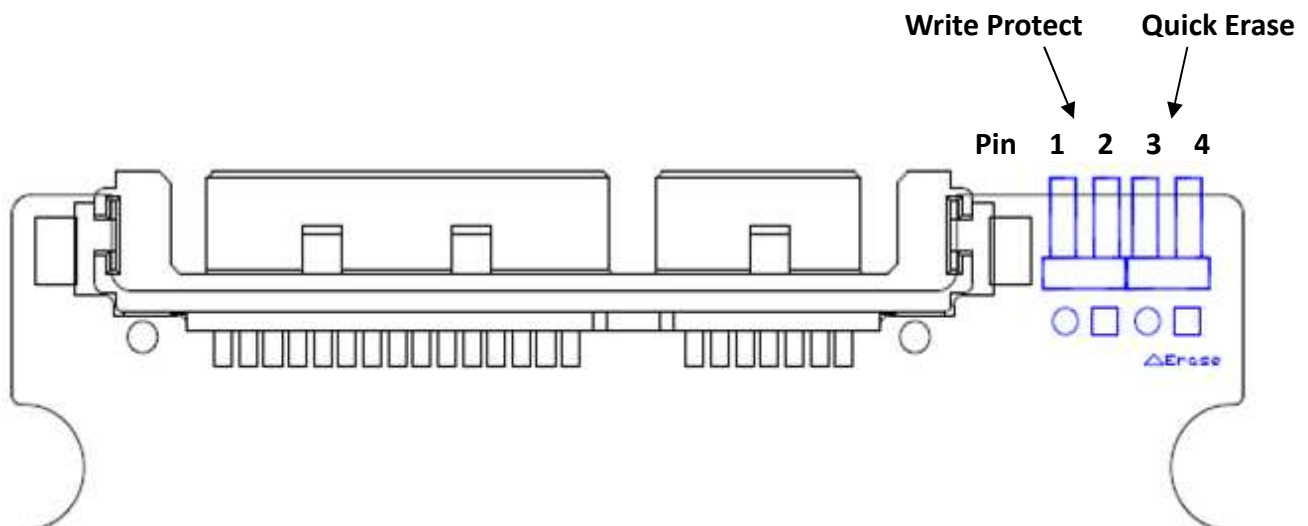

7. ACROMYIM



The following table is to list out the acronyms that have been applied throughout the document.

Term	Definitions
ATTO	Commercial performance benchmark application
DEVSLP	Device Sleep Mode
DIPM	Device initiated power management
HIPM	Host initiated power management
LBA	Logical block addressing
MB	Mega-byte
MTBF	Mean time between failures
NCQ	Native command queue
PLP	Power Loss Protection
SATA	Serial advanced technology attachment
S.M.A.R.T.	Self-monitoring, analysis and reporting technology
SSD	Solid state disk

8. PART NUMBER DECODER



SFD-2ACX¹X²X³X⁴X⁵X⁶X⁷X⁸

Item		Series	Capacity (Byte)	NAND Flash	Option
			X ¹ X ² X ³ X ⁴ X ⁵	X ⁶	X ⁷ X ⁸
SFD	2	AC	0016G 0032G 0060G 0064G 0120G 0128G 0240G 0256G 0480G 0512G 0960G 0001T 1920G 0002T	A : 3D TLC Standard (0°C to +70°C) B : 3D TLC Industrial (-40°C to +85°C) V : 3D pSLC Standard (0°C to +70°C) W : 3D pSLC Industrial (-40°C to +85°C)	

X⁷X⁸

Blank: Standard

- 01: Write Protection (WP)
- 03: Quick Erase Jumper (QEJ)
- 06: Conformal Coating (CC)
- 07: CC + WP
- 09: CC + QEJ
- 20: Power Loss Protection (PLP)
- 21: PLP + CC
- 24: PLP + QEJ
- 30: DEVSLP Function
- 35: PLP + WP
- 36: PLP + WP + CC